

Prepared by:-	M.Davies	Approved by:-		Date: 09/09/14
REV NO:-	1			
ECO:-	4282			

INTRODUCTION

The Hi-Force SCP range of self- contained hydraulic pullers is designed and manufactured to the highest industry standards and has proven to be an extremely versatile tool for a wide range of applications, including removing press fit parts such as wheels, gears, sprockets, sleeves, pulleys and other similar items. The range offers 3 models, each with integral manually operated hydraulic pump and multi-position operating handle. The completely sealed hydraulic system of the SCP hydraulic pullers enables use of the tool in any position. Each unit is supplied with a safety cover, to prevent flying debris during operation.

SAFETY NOTES

Max capacity:

SCP103 10 tonnes

SCP203 20 tonnes

SCP303 30 tonnes

- Safety glasses must be worn by anyone in sight of the puller.
- Pullers should only be used by persons familiar with them.
- Ensure that the correct capacity and size of puller is used for the job.
- Always apply force gradually.

Sufficient time must be allowed for set up to ensure that the puller is centrally positioned on the component being pulled. Incorrect alignment may result in a dangerous operating situation due to the high hydraulic pressures involved.

NOTE: Pullers have a 2/3-way combination puller head. It is strongly recommended that the 3 jaw combination be used whenever possible. The 3 jaw combination allows a better distribution of puller force as well as a better grip of the component.

PULLER SETUP AND OPERATION

1. Select the correct capacity and size puller for the job. This is determined by measuring 'reach' and 'diameter' of the component being pulled.

MODEL	Reach	Dia MIN	Dia MAX
SCP103	195	30	250
SCP203	275	50	360
SCP303	405	100	410

Prepared by:-	M.Davies	Approved by:-		Date: 09/09/14
REV NO:-	1			
ECO:-	4282			

2 Place the handle assembly into the handle clevis.
See Figure 1.

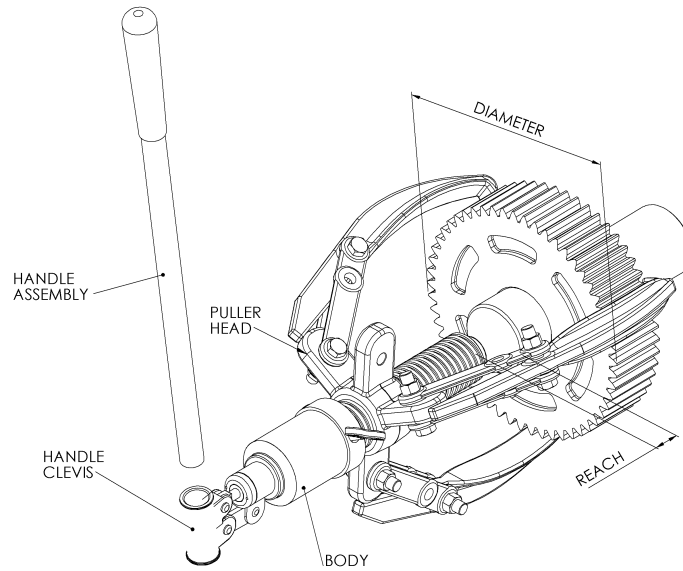

FIGURE 1.

3 Turn the control valve knob completely clockwise to allow the piston to advance.

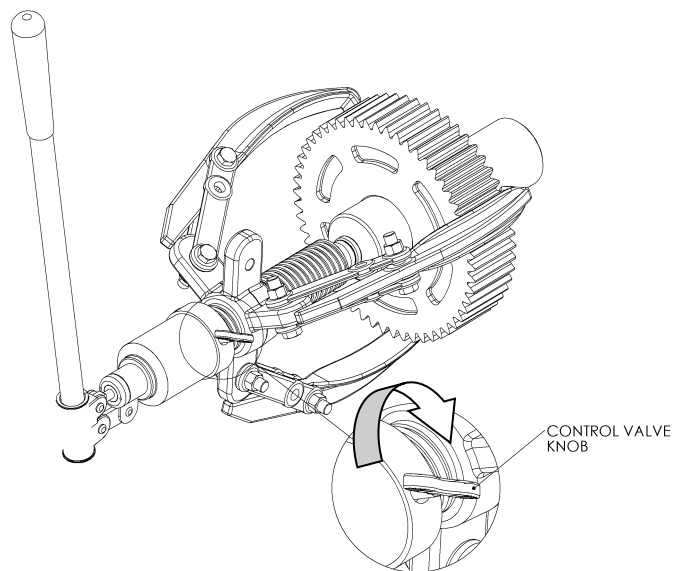

FIGURE 2.

Prepared by:-	M.Davies	Approved by:-		Date: 09/09/14
REV NO:-	1			
ECO:-	4282			

IMPORTANT: Ensure that the control valve knob is not in contact with the puller head and that it can be turned freely.

4. Position the puller and puller jaws around the component to be pulled, adjusting the puller straps and jaws as required. Take up any slack by threading the puller head further down the puller body.

Begin pumping the handle to advance the piston, making any final adjustments to ensure correct alignment with the component being pulled.

5. The handle assembly rotates a full 360° to allow the best position for the job.
See Figure 3.

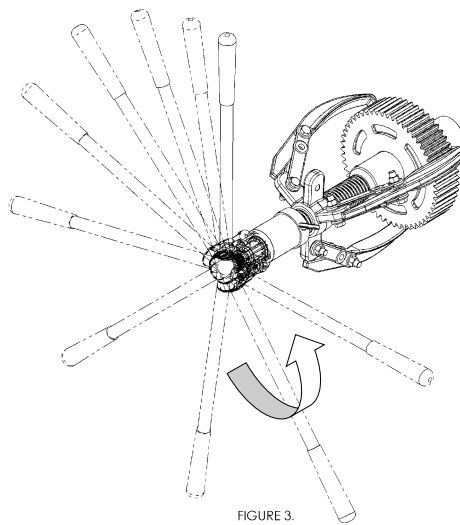

FIGURE 3.

6. Advance the piston until the part is removed making sure to support the puller body with one hand.
See Figure 4.

Prepared by:-	M.Davies	Approved by:-		Date: 09/09/14
REV NO:-	1			
ECO:-	4282			

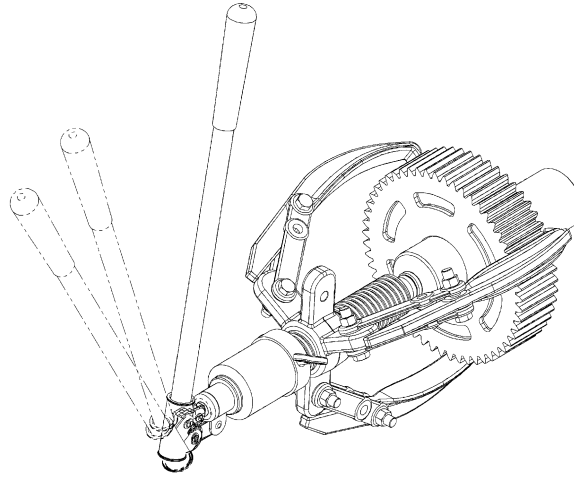

FIGURE 4.

7. Once component is removed, turn the control knob completely anticlockwise to retract the piston. See figure 6.

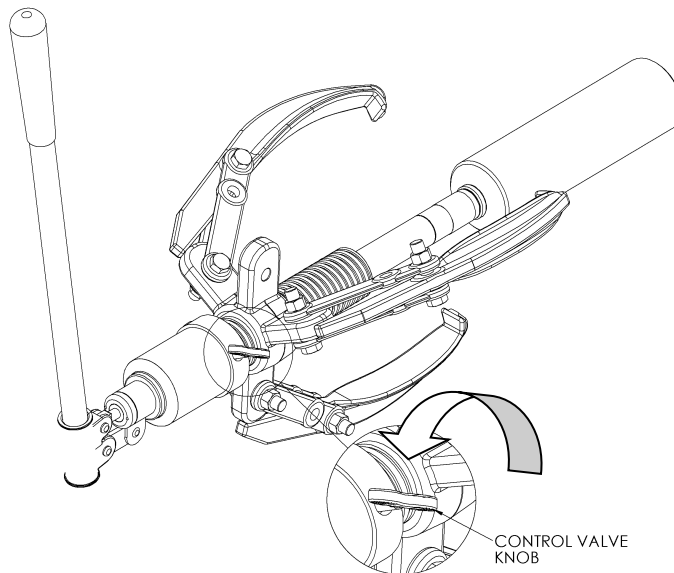

FIGURE 6.

Prepared by:-	M.Davies	Approved by:-		Date: 09/09/14
REV NO:-	1			
ECO:-	4282			

UK Head Office:

**Hi-Force Limited
Prospect Way
Daventry
Northamptonshire
NN11 8PL
United Kingdom**

Tel: + 44 1327 301000**Fax: + 44 1327 706555****Email: daventry@hi-force.com****Hi-Force Regional Offices:**

**Hi-Force Australia Pty. Ltd
Rockingham
Australia
Tel: +61 8 9591 1288
Email: australia@hi-force.com**

**Hi-Force Caspian
Baku
Azerbaijan
Tel: +994 12 447 4100
Email: baku@hi-force.com**

**Hi-Force Hydraulics (Asia) S.B
Selangor
Malaysia
Tel: +603 5569 4209
Email: malaysia@hi-force.com**

**Hi-Force Nederland BV
Strijen
Netherlands
Tel: +31 78 6745488
Email: holland@hi-force.com**

**Hi-Force Hydraulics (Pty) Ltd
Midrand
South Africa
Tel: +27 11 314 0555
Email: south.africa@hi-force.com**

**Hi-Force FZCO
Dubai
United Arab Emirates
Tel: +971 4 815 0600
Email: dubai@hi-force.com**

**Hi-Force Hydraulics
Abu Dhabi
United Arab Emirates
Tel: +971 2 551 3100
Email: abu.dhabi@hi-force.com**

**Hi-Force Hydraulic Equipment
(Shanghai) Ltd. Co.
Shanghai, China
Tel: +86 21 6697 3010
Email: china@hi-force.com**