

## HGG - SINGLE ACTING LOAD RETURN INDUSTRIAL CYLINDERS



Capacities from 152 to 326 tonnes

Stroke length 155mm

Working pressure 700 Bar

The HGG range of load return industrial cylinders is specifically designed for lifting and maintenance applications. These single acting cylinders are supplied with a tilting saddle to reduce risks of damage caused by side loading and an integral stop ring for stroke limitation is fitted as standard. Standard range models are featured in this catalogue, however additional capacities and stroke options are available on request.

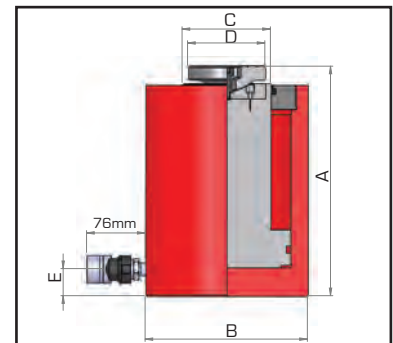

Model number	Capacity tonnes	Stroke mm	Oil cap. litres	Cyl. eff. area cm <sup>2</sup>	Weight kg
<b>HGG1506</b>	152	155	3.32	214.3	58.3
<b>HGG2006</b>	203	155	4.63	285.1	95.3
<b>HGG3006</b>	326	155	7.10	457.7	153.5

Dimensions in mm (unless otherwise stated)				
A	B	C	D	E
297	210	114	100	37
310	254	140	135	50
343	312	165	150	50

B

## HSG - SINGLE ACTING LOAD RETURN CONSTRUCTION CYLINDERS



Capacities from 152 to 326 tonnes

Stroke length 152 to 153mm

Working pressure 700 Bar

The HSG single acting load return construction cylinders are ideally suited for construction, civil engineering, heavy fabrication and maintenance applications. These cylinders are supplied with a tilting saddle fitted as standard and have a stroke limitation device incorporated for safety. Standard range models are featured in this catalogue, however additional capacities and stroke options are available on request.

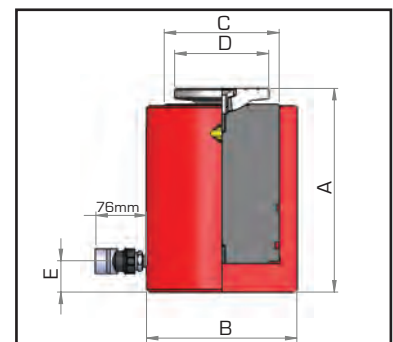

Model number	Capacity tonnes	Stroke mm	Oil cap. litres	Cyl. eff. area cm <sup>2</sup>	Weight kg
<b>HSG1506</b>	152	152	3.21	214.3	77.5
<b>HSG2006</b>	203	152	4.34	285.1	107.7
<b>HSG3006</b>	326	153	6.99	457.7	175.2

Dimensions in mm (unless otherwise stated)				
A	B	C	D	E
293	216	165.1	135	45
296	254	190.5	135	45
326	312	241.3	150	50