



High flow 3-stage pump unit

Choice of air or electric power options

Rigid, compact & lightweight

The Hi-Force TPA & TPE range of high speed torque wrench pumps offers the following features:

F

- >> High speed 3-stage, 8 piston pump unit
- >> Multi outlet 4-way split block for simultaneous operation of 4 hydraulic wrenches
- >> Compact design, completely fitted within a rigid protection & carrying frame
- >> Automatically activated oil cooling heat exchanger fitted as standard on all models
- >> Adjustable pressure relief valve with locking nut for setting maximum system pressure
- >> Models with suffix 'A' fitted with analogue pressure gauge
- >> Models with suffix 'D' fitted with pressure transducer and digital pressure gauge
- >> Manual with auto retract or full automatic cycle operation, all controlled from Pendant: (automatic cycle functions only available on electric driven models)
- >> Solenoid valve with pendant control ( 5 metre cable), including motor on/off

Model number	Max. pressure Bar	Power supply	Pressure gauge	Gauge reading [*]	Displacements l / m		
					1st stage 0-65 bar	2nd stage 65-325 bar	3rd stage 325-700 bar
Air driven pump units							
<b>TPA07A</b>	700	7.0 Bar air	analogue	Bar/PSI	7.0	1.6	0.80
<b>TPA07D</b>	700	7.0 Bar air	digital	Bar/PSI/Nm/Lbf.Ft	7.0	1.6	0.80
Electric driven pump units							
<b>TPE15A</b>	700	110V-1Ph-50Hz	analogue	Bar/PSI	6.5	1.5	0.75
<b>TPE15D</b>	700	110V-1Ph-50Hz	digital	Bar/PSI/Nm/Lbf.Ft	6.5	1.5	0.75
<b>TPE16A</b>	700	120V-1Ph-60Hz	analogue	Bar/PSI	7.8	1.8	0.90
<b>TPE16D</b>	700	120V-1Ph-60Hz	digital	Bar/PSI/Nm/Lbf.Ft	7.8	1.8	0.90
<b>TPE25A</b>	700	230V-1Ph-50Hz	analogue	Bar/PSI	6.5	1.5	0.75
<b>TPE25D</b>	700	230V-1Ph-50Hz	digital	Bar/PSI/Nm/Lbf.Ft	6.5	1.5	0.75
<b>TPE26A</b>	700	230V-1Ph-60Hz	analogue	Bar/PSI	7.8	1.8	0.90
<b>TPE26D</b>	700	230V-1Ph-60Hz	digital	Bar/PSI/Nm/Lbf.Ft	7.8	1.8	0.90
<b>TPE45A</b>	700	400V-3Ph-50Hz	analogue	Bar/PSI	6.5	1.5	0.75
<b>TPE45D</b>	700	400V-3Ph-50Hz	digital	Bar/PSI/Nm/Lbf.Ft	6.5	1.5	0.75
<b>TPE46A</b>	700	480V-3Ph-60Hz	analogue	Bar/PSI	7.8	1.8	0.90
<b>TPE46D</b>	700	480V-3Ph-60Hz	digital	Bar/PSI/Nm/Lbf.Ft	7.8	1.8	0.90

Note: [\*] Torque value reading only available on software controlled, programmable pump unit  
Digital versions coming soon



Maximum working pressure 700 Bar

High speed, 3-stage pump

Multi-outlet block for operation of 4 wrenches

- >> Optional extras include a full software controlled pump unit, enabling the user to select the hydraulic torque wrench in use via the digital display and have torque readings (in Nm or Lbf.ft) on the digital gauge. All Hi-Force TWS-N and TWH-N hydraulic torque wrenches are programmed and selectable as standard.

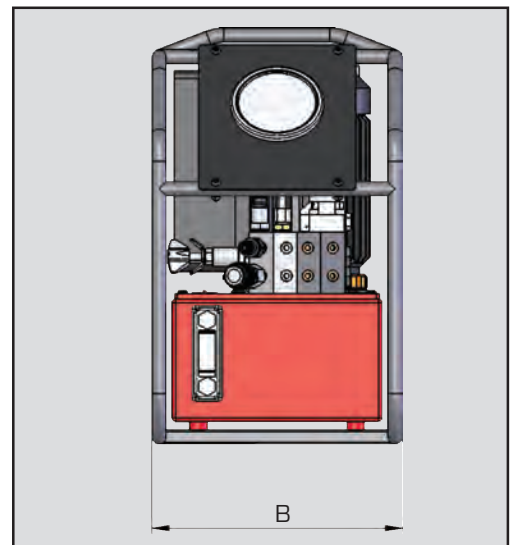
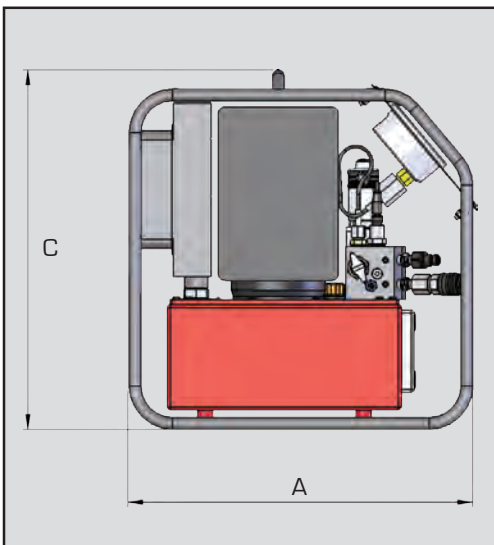

Specifications (all models)				Dimensions in mm		
Oil capacity	Max. noise level	Max. oil temp	Weight incl. oil	Length (A)	Width (B)	Height (C)
7 litres	88 db (A)	80° C	36 kg	456	286	476

Optional coupler sets for simultaneous operation of multiple torque wrenches

Model number	Description
<b>TP-CS1</b>	Single set of male / female flatface couplers, for simultaneous operation of two hydraulic wrenches
<b>TP-CS2</b>	Double set of male / female flatface couplers, for simultaneous operation of three hydraulic wrenches
<b>TP-CS3</b>	Triple set of male / female flatface couplers, for simultaneous operation of four hydraulic wrenches