

**HFA | SINGLE ACTING FAILSAFE LOCK RING ALUMINIUM CYLINDERS**



Capacities from 32 to 110 tonnes

Stroke lengths from 51 to 305 mm

Working pressure 700 bar

\*see pages 24 and 25  
*Note:* Lifting eyes fitted on 110 tonne models

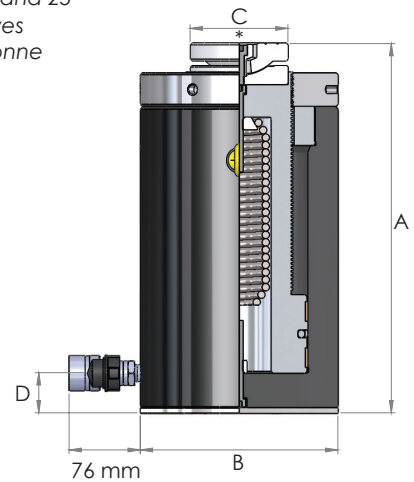

- ▶ Lightweight aluminium cylinders for applications where weight and portability are of prime importance
- ▶ Single acting, spring assisted return
- ▶ Mechanical lock ring feature allows for load holding for extended periods
- ▶ Hard anodised piston rod and cylinder for corrosion resistance and increased durability
- ▶ Low friction bearing surfaces
- ▶ Anti-extrusion seals for improved performance at high pressures
- ▶ Tilting saddle fitted as standard on all models
- ▶ Steel base plate fitted as standard
- ▶ Integral stop ring
- ▶ Optional piston rod saddles listed on pages 24 and 25

Model number	Capacity (tonnes)	Stroke (mm)	Oil capacity (cm <sup>3</sup> )	Cylinder eff. area (cm <sup>2</sup> )	Weight (kg)	Tommy bar	Dimensions (mm)			
							A	B	C	D
HFA302	32	51	232	45.4	6	TTB10	227	108	50	20
HFA306	32	152	691	45.4	8	TTB10	328	108	50	20
HFA3012	32	305	1386	45.4	11	TTB10	481	108	50	20
HFA502	51	51	364	71.3	9	TTB10	231	133	70	25
HFA506	51	152	1084	71.3	11	TTB10	332	133	70	25
HFA5012	51	305	2175	71.3	17	TTB10	485	133	70	25
HFA1002	110	51	785	153.9	24	TTB10	277	202	100	35
HFA1006	110	152	2340	153.9	30	TTB10	378	202	100	35
HFA10012	110	305	4695	153.9	39	TTB10	531	202	100	35

*Note:* Other capacities and stroke lengths available on request