



30	2	3 30 23 060 00 5	
40	2	4 20 19 005 05 2	
50	2	4 30 35 024 05 5	
60	4	4 24 43 004 05 7	
70	1	3 13 05 411 00 0	
80	1	3 02 40 267 00 0	- USA
80	1	3 13 05 412 00 0	- USA
90	1	3 14 20 016 00 1	- USA
90	1	3 14 20 119 00 0	
300	1	3 12 09 013 00 2	
340	1	4 17 01 607 01 2	
350	1	3 01 10 021 01 8	
355	1	3 01 10 021 01 8	
360	2	3 02 16 099 00 6	
370	2	3 36 13 075 00 3	
380	2	4 17 15 017 00 8	
410	1	3 38 04 015 00 5	
420	2	4 30 02 108 99 7	
430	1	4 17 01 010 03 2	
440	1	4 02 21 008 00 3	
450	1	4 26 41 001 00 2	
465	1	3 38 09 142 01 9	
470	1	3 26 24 087 02 8	
470	1	3 26 24 087 03 4	
490	1	3 26 24 086 02 4	
490	1	3 26 24 086 03 0	
500	1	4 02 21 017 00 4	
510	1	3 34 05 022 00 3	
515	1	3 34 05 022 01 2	
517	1	3 34 05 022 02 8	
520	1	3 02 17 200 00 4	
530	1	4 17 24 001 00 5	
550	1	3 24 08 212 00 6	
560	1	4 26 16 006 00 7	
580	1	4 17 01 222 03 8	
590	1	4 20 19 006 08 0	
620	1	3 24 19 063 00 0	
630	1	4 26 16 003 00 2	
640	2	4 02 47 006 00 2	
660	4	4 30 35 073 05 2	
660	13	4 24 43 004 05 7	
680	1	3 24 08 232 00 4	
690	2	4 02 47 007 00 6	
700	1	3 24 29 068 00 6	
705	1	3 24 29 068 01 9	

770	1	3 27 14 057 00 2	
775	1	3 27 14 057 01 1	
780	1	3 27 14 059 00 4	
790	2	4 30 35 080 06 8	
800	1	4 02 01 036 00 6	
810	2	4 30 07 038 08 8	
820	1	3 27 14 011 00 0	
830	2	4 20 01 009 08 0	
840	2	4 24 01 018 06 9	
850	4	4 02 38 041 00 5	
860	2	4 24 45 003 06 0	
870	2	4 20 01 029 06 6	
880	2	4 30 33 015 05 2	
890	8	4 30 35 073 05 2	
900	4	3 16 04 008 00 1	
910	2	3 27 14 058 00 0	
920	1	3 06 04 042 00 7	
1400	1	3 13 05 365 00 0	
1410	1	3 13 05 366 00 0	
1420	1	3 13 05 367 00 0	
1430	1	3 13 05 368 00 0	
1450	1	3 13 05 370 00 0	
1460	1	3 13 05 371 00 0	
1470	1	3 13 05 372 00 0	
1480	1	3 13 05 373 00 0	
1490	1	3 13 05 374 00 0	
1500	1	3 13 05 375 00 0	
1510	1	3 13 05 376 00 0	
1520	4	3 13 05 377 00 0	
1530	1	3 13 05 378 00 0	
1540	1	3 13 05 379 00 0	
1550	1	3 13 05 380 00 0	
1560	1	3 13 05 381 00 0	
1570	1	4 26 16 006 00 7	
1580	1	3 13 05 382 00 0	
1590	2	3 13 05 383 00 0	
1600	1	3 13 05 384 00 0	
1610	1	3 13 05 385 00 0	
1620	2	3 13 05 386 00 0	
1630	1	3 13 05 387 00 0	
1640	4	3 13 05 388 00 0	
1650	1	3 13 05 389 00 0	
1660	1	3 13 05 390 00 0	
1670	4	4 24 01 003 06 3	
1680	4	4 30 35 034 06 7	

1690	1	3 13 05 391 00 0	
1700	1	3 13 05 392 00 0	
1710	1	3 13 05 393 00 0	
1720	1	3 13 05 394 00 0	
1730	1	3 34 12 015 00 0	
1735	1	3 34 12 015 01 9	
1736	1	3 13 05 395 00 0	
1740	1	3 05 10 025 00 4	
1745	1	3 13 05 396 00 0	
1750	1	3 09 01 113 00 8	
1755	1	3 13 05 397 00 0	
1760	1	3 26 01 193 00 8	
1765	1	3 13 05 398 00 0	
1770	1	3 13 05 399 00 0	
1780	1	3 13 05 400 00 0	
1790	1	3 13 05 401 00 0	
1800	2	3 13 05 402 00 0	
1810	1	3 13 05 403 00 0	
1820	1	3 13 05 404 00 0	
1830	1	3 13 05 405 00 0	
1840	1	3 13 05 406 00 0	
1850	1	3 13 05 407 00 0	
1860	1	3 13 05 408 00 0	
1870	1	3 13 05 409 00 0	
1880	1	3 13 05 410 00 0	
5000	1	3 21 19 044 01 2	
5010	1	3 21 19 044 00 3	
5020	1	3 32 11 022 00 1	
5030	1	4 24 01 005 10 8	
5040	1	4 30 01 059 10 2	
5050	1	4 20 19 007 10 5	
5060	2	4 30 35 014 05 6	
5070	1	4 11 40 004 00 7	
5080	2	6 35 03 063 00 7	
5090	1	6 29 01 007 00 7	
5100	1	6 29 06 009 00 7	
5110	1	6 29 07 010 00 0	
6000	1	3 21 32 007 01 1	
9000	1	3 41 01 062 06 0	
9010	1	3 41 51 062 06 0	



# Service Information

004-2007

7 534 08 - STS 325 R

<p>DE:                  Produktoptimierung der oben genannten Maschine:  <b>Verbesserter Korrosionsschutz des DL-Motors</b>                  Maßnahme:                  Die in Abbildung 1 dargestellten Teile sind durch den DL-Motor-Umbausatz 3 13 05 420 01 0 Pos. 1472 (Abbildung 2) zu ersetzen bzw. zu ergänzen.</p>	<p>EN:                  Product optimization of the above listed machine:  <b>Improved corrosion protection of the DL motor</b>                  Measure:                  The components shown in Fig. 1 are to be replaced/supplemented by the DL-motor modification kit 3 13 05 420 01 0 Pos. 1472 (Fig. 2).</p>
<p>FR:                  Optimisation du produit de l'appareil mentionné ci-haut :  <b>Protection anti-corrosion améliorée du moteur à air comprimé</b>                  Mesure :                  Les pièces représentées dans figure 1 doivent être remplacées ou complétées par les set de modification du moteur à air comprimé 3 13 05 420 01 0 pos. 1472 (figure 2).</p>	<p>ES:                  Mejora de calidad de la máquina arriba citada:  <b>Protección contra corrosión mejorada del motor neumático</b>                  Medida:                  La piezas representadas en la figura 1 deberán sustituirse o completarse con las piezas del kit de transformación 3 13 05 420 01 0, pos. 1472 (figura 2) del motor neumático.</p>

alt/old/vieux/viejo ← 06/07

1470	3 13 05 372 00 0
1480	3 13 05 373 00 0
1580	3 13 05 382 00 0



Abb./Fig. 1

neu/new/nouveau/nuevo → 06/07

1472 3 13 05 420 01 0

1470	3 13 05 420 00 0
1475	3 13 05 421 00 0
1480	3 13 05 423 00 0
1485	3 13 05 422 00 0
1580	3 13 05 419 00 0
1585	3 13 05 417 00 0

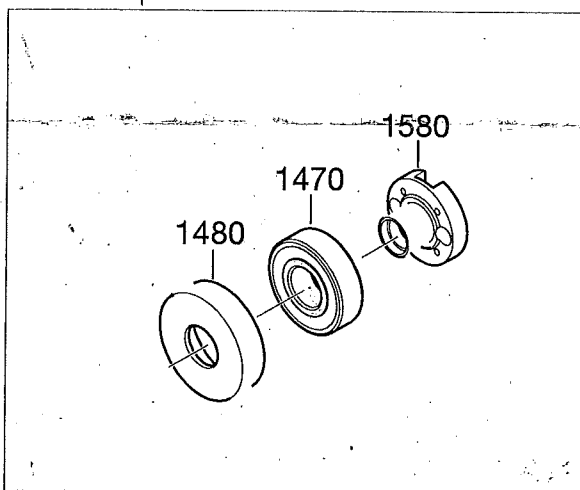

Abb./Fig. 2

⚠ **Diese Information bei der jeweiligen Ersatzteilliste einordnen!**  
**Please add this information to the corresponding spare parts list!**  
**Mettre cette information dans la liste correspondante des pièces de rechange !**  
**¡Adosar esta información a la respectiva lista de piezas de repuesto!**



Information zur Instandhaltung von FEIN-Elektrowerkzeugen  
 Information for the repair of FEIN Electric Power Tools  
 Informations sur la réparation d'outils électriques FEIN

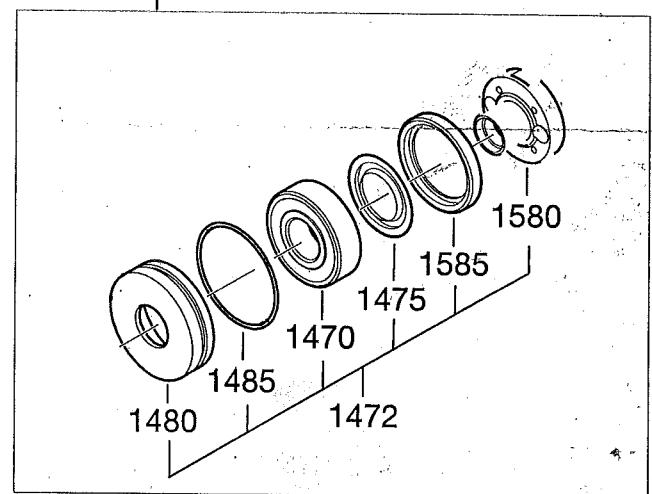

Verteiler: NL, Vertragswerkstätten  
 Distributed to: FEIN authorized workshops, representatives, subsidiaries  
 Destinataires: Réparateurs agréés FEIN, filiales, agences

Bauart: STS 325R  
 Type:  
 Modèle:

Betrifft: / Re: / Concerne: DL-Motor / pneumatic motor / moteur pneumatique

Alte  
 Ausführung  
 old version  
 vieille version

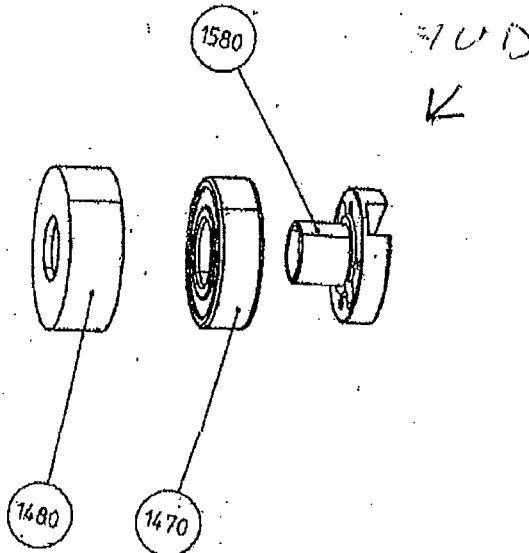

Neue  
 Ausführung  
 new version  
 nouvelle version

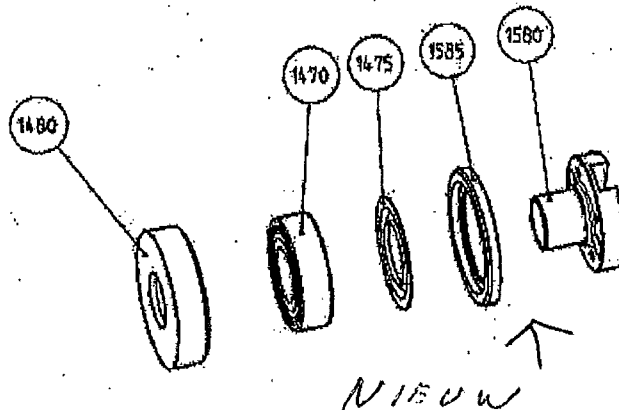

Achtung: Diese Information bei der jeweiligen Bedienungs- bzw. Reparaturanleitung einordnen!  
 Attention: Please add this information to the corresponding operating instructions!  
 Attention: Veuillez ajouter cette information au mode d'emploi respectif!

C. & E. FEIN GmbH	Nummer/number/numéro	Datum/date/date	Gefertigt/made by/etabl par	Geprüft/checked by/contrôle par
	3 41 30 332 06.0	04.04.06	Herrmann	

OD 1007 / 04.96